

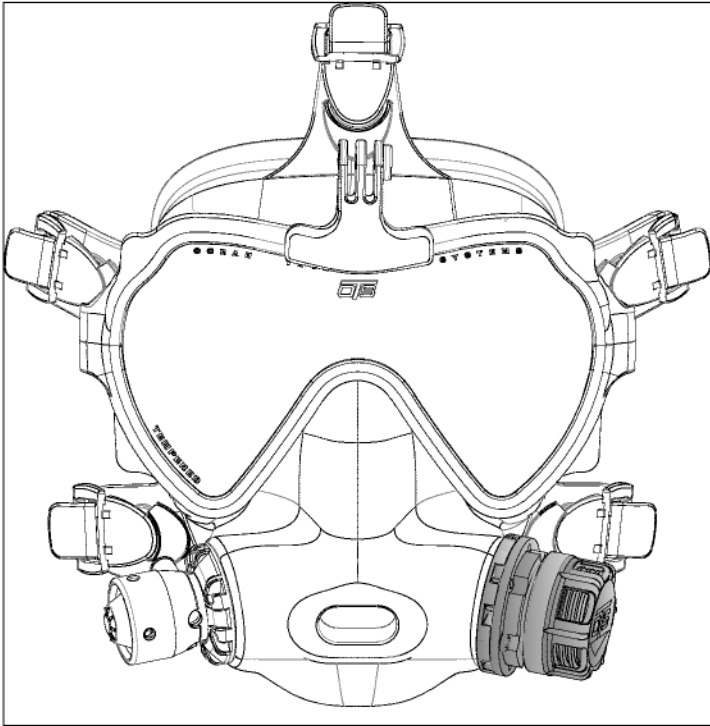

**Spectrum Full-Face Mask
Ambient Breathing Valve Installation Guide**

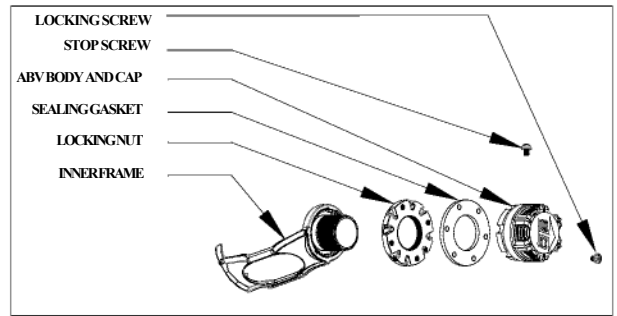

What's Included:



Introduction:

The Ambient Breathing Valve (ABV®) allows the diver to breathe ambient air while at the surface conserving the diver's air supply.

To use, simply open the valve while above water to breathe ambient air and close it when ready to dive.

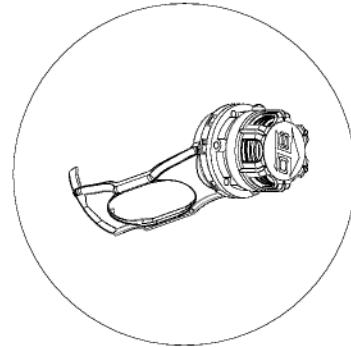

Installation instructions:

1: Remove the existing inner frame from the mask, then insert the supplied ABV® inner frame.

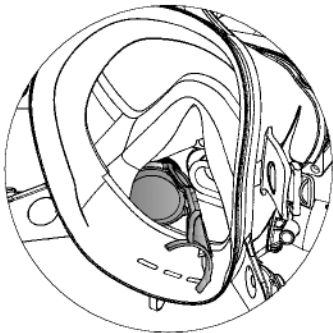

2: Thread locking nut onto innerframe. Using the supplied wrench, tighten the locking nut firmly onto the mask.

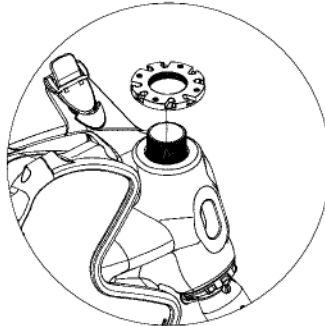

3: Slide the rubber sealing gasket over the locking nut.

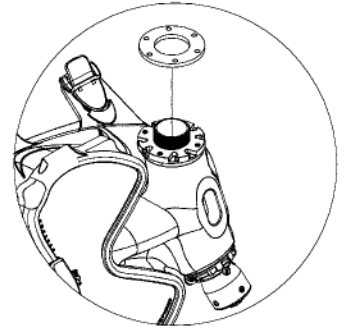

4: Thread the ABV® body onto the mask. Tighten firmly to ensure that the ABV® does not leak when submerged.

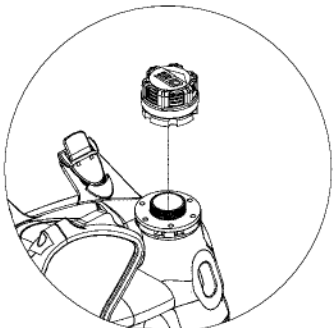

5: Align mounting holes, then using a screw driver, thread the locking screw into the mounting holes to lock the ABV in place.

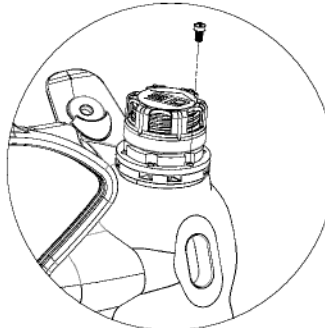

NOTE : Do not overtighten the ABV® cap! Overtightening the ABV® can cause the cap to become difficult to open.

⚠

DO NOT DIVE SPECTRUM FFM IF ABV® IS LEAKING WATER. TIGHTEN OR RE-INSTALL THE ABV® IF THERE IS SIGN OF WATER LEAKAGE.

SERIOUS INJURY OR DEATH CAN OCCUR.

Operations Instructions:

To operate the ABV®, turn the cap counter-clockwise to open valve. With the cap open, the mask is open to the ambient air. This allows the diver to breathe ambient air, preserving air supply.

When ready to dive, simply turn the ABV® cap clockwise to close the cap and breathe from air supply. Ensure that the cap is sealed tightly before diving.

NOTE : Do not overtighten the ABV®! Overtightening the ABV® can cause the cap to become difficult to open.

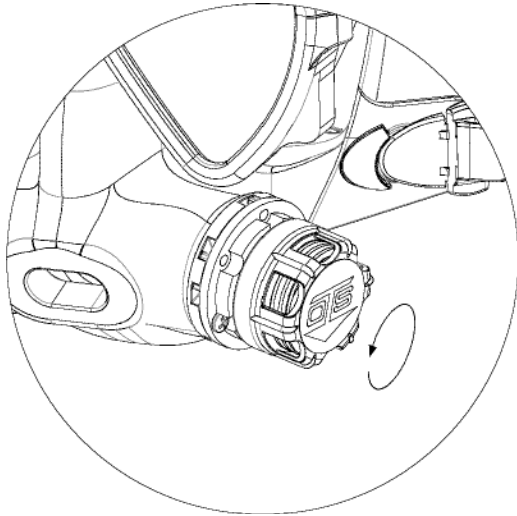

Maintenance Instructions:

The following maintenance steps should be performed annually.

1: Remove the ABV® cap by unscrewing stop screw. Rotate the ABV® cap counter-clockwise until the cap is completely removed from the body.

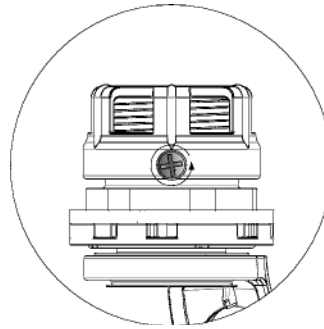

2: Remove the O-ring in the ABV® body and replace with a new O-ring. Lightly lubricate the new O-ring with a high grade silicone grease.

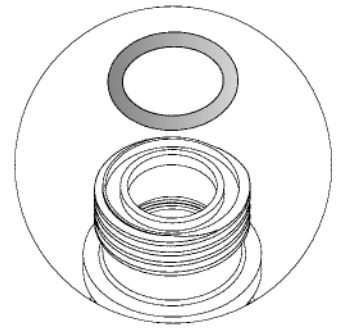

3: Remove check valve from the inner frame and replace with a new valve by pulling the small tab through the valve seat with a pair of needle nose pliers.

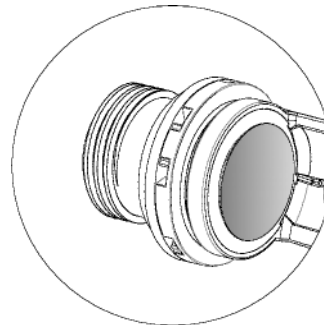

4: Ensure that the ABV® is free from dirt and debris. Reassemble the ABV® and test for leaks. The ABV® is now maintained and ready to dive.

ABV® Maintenance Kits can be ordered from OTS using P/N : 900466-000

Please contact OTS or your local authorized OTS Dealer for pricing / availability of ABV® Maintenance Kits



- IMPORTANT SAFETY NOTICE (Please read before using the product.)

It is absolutely essential that all divers are properly trained and equipped and fully understand these instructions before attempting to use the Ambient Breathing Valve (ABV®).

While the ABV® provides divers the ability of surface air breathing, it does not change or eliminate the potential hazards of diving.

NOTE: This instruction sheet and the information contained herein are provided for use as an operation and maintenance guide. No license or rights to manufacture, reproduce, and/or sell either the instruction sheet or the articles described herein are given. Ocean Technology Systems reserves the right to change specifications without notice.

Ocean Technology Systems
3133 W. Harvard Street • Santa Ana • California • 92704
• USA Toll-free (800) 550-1984 • Telephone • (714) 754-7848 • Fax (714) 966-1639 E-mail ots@otscomm.com
• Web www.otscomm.com

Undersea Systems International, Inc.
dba

Ocean Technology Systems

LIMITED WARRANTY

The Spectrum Full-Face Mask ABV® is fully warranted against defects in materials and workmanship, including labor, for a period of one year from the time of purchase. Our obligation under this warranty is limited to the replacing of any part or parts which prove to our satisfaction to have been defective and which have not been misused or carelessly handled.

You must contact an official Ocean Technology Systems (OTS) Service Center or OTS directly to obtain service. If you elect to send the item/s to OTS, you must call and obtain an RMA number from our Repair department. The complete unit and/or damaged part shall be returned to our factory, transportation charges prepaid. We reserve the right to decline responsibility where repairs have been made or attempted by any party other than an OTS service factory trained center or properly trained personnel.

In no event shall OTS be liable for consequential damages related to our product/s.

Warranty registration is required. Any parts requiring replacement due to excessive wear or damage are not covered in this offer. Customer will be notified of any additional charges for worn or damaged components. The customer is responsible for shipping charges to the factory. OTS will pay shipping limited to the continental United States via UPS Ground service or equivalent. Any other shipping requirements are the responsibility of the customer.

Undersea Systems International, Inc.
dba

Ocean Technology Systems

3133 West Harvard St., Santa Ana, CA 92704 USA
Telephone: 714.754.7848 Fax: 714.966.1639

E-Mail: ots@otscomm.com

Web: www.otscomm.com

© Copyright 2018 by Undersea Systems International, Inc., dba Ocean Technology Systems. All rights reserved. Specifications subject to change without prior notice. Part Number : 506278-000 B